

REMOTE MOUNTED VAPOR ACTUATED DIAL THERMOMETER - 4 1/2" DIAL MODEL VR45P

STANDARD FEATURES

- 4 1/2" dial size
- Glass reinforced Phenolic case
- Stainless steel snap ring
- Glass lens
- Aluminum dial, white finish, black markings
- Progressive graduations offer ideal reading in the upper two thirds of the range
- For standard ranges see page 23
- Adjustable pointer
- Precision geared brass movement
- + or 1 scale division accuracy
- 5ft. bronze braided capillary tubing standard. Additional tubing lengths and materials available
- Brass thermowell, 1/2" NPT standard. 2" "U" dimension below thread. Additional sizes, threads and materials available. See page 23.



MODEL VR45P

STANDARD RANGES

CODE	FAHRENHEIT
01	-40/65F
02	-20/120F
03	20/220F
04	30/300F

CODE	CELSIUS
05	-40/20C
06	0/100C

CODE	DUAL SCALE F & C
07	-40/65F & -40/20C
08	-20/120F & -30/50C
09	20/220F & 0/105C
10	30/300F & 0/150C

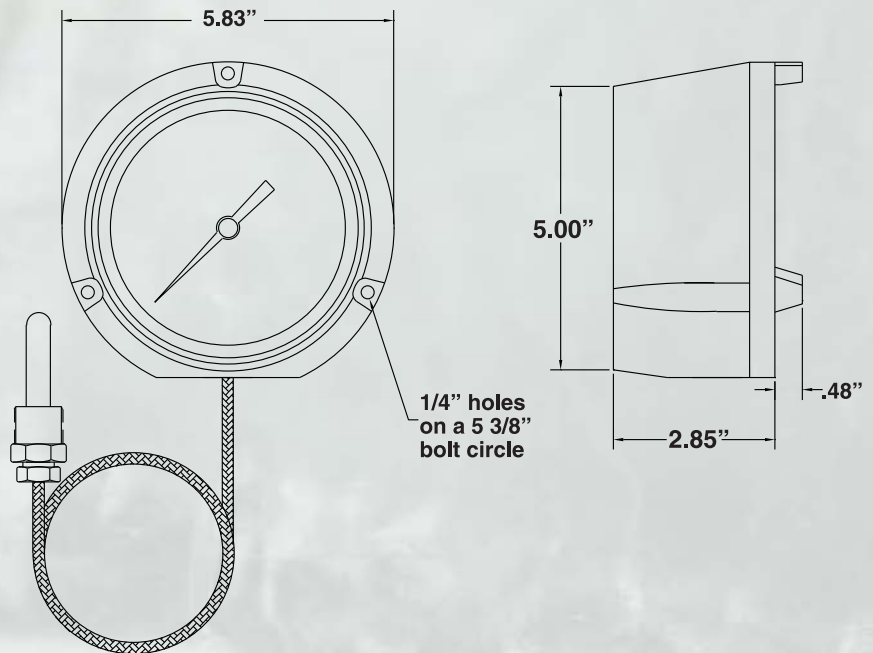

HOW TO ORDER - PLEASE SPECIFY THE FOLLOWING:

MODEL #	RANGE CODE	TUBING LENGTH	IMMERSION LENGTH	THERMOWELL CATALOG NO.
VR45P	2 digit code from table	05 = 5 FT. 10 = 10 FT. ETC.	2 = 2" 4 = 3 1/2"	See Page 23

ADJUST-ANGLE VAPOR ACTUATED DIAL THERMOMETER - 4 1/2" DIAL MODEL VA45S

STANDARD FEATURES

- 4 1/2" dial size
- Stainless steel case and ring
- Acrylic lens
- Aluminum dial, white finish, black markings
- Progressive graduations offer ideal reading in the upper two thirds of the range
- For standard ranges see page 23
- Adjustable pointer
- Precision geared brass movement
- + or -1 scale division accuracy
- Brass thermowell, 1/2" NPT standard. 2" "U" dimension below thread. Additional sizes, threads and materials available. See page 23.



◀ **MODEL VA45S**

STANDARD RANGES

CODE	FAHRENHEIT
01	-40/65F
02	-20/120F
03	20/220F
04	30/300F

CODE	CELSIUS
05	-40/20C
06	0/100C

CODE	DUAL SCALE F & C
07	-40/65F & -40/20C
08	-20/120F & -30/50C
09	20/220F & 0/105C
10	30/300F & 0/150C

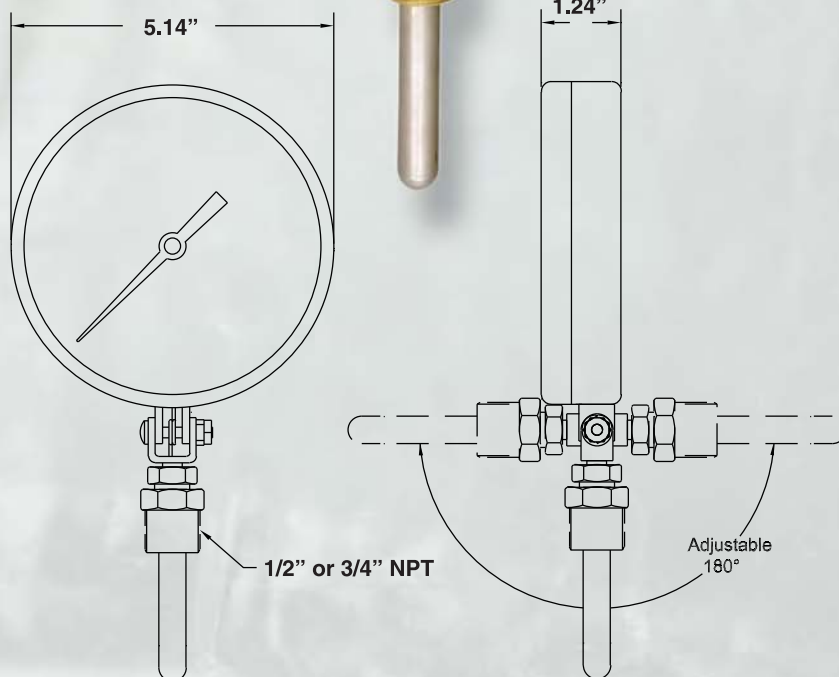

21

HOW TO ORDER - PLEASE SPECIFY THE FOLLOWING:

MODEL #	RANGE CODE	IMMERSION LENGTH	THERMOWELL CATALOG NO.
VA45S	2 digit code from table	2 = 2" 4 = 3 1/2"	See Page 23